



**DOVER SERIES**  
**Wall Mount Offset**  
**Back Plate Hinge**  
52036

**PRODUCT NAME:** DOVER - Wall Mount Offset Back Plate Hinge

**PRODUCT CODE:** 52036

**MATERIAL:** All-brass construction

**KEY FEATURES:** Heavy Duty Shower Hinge.  
Glass to wall.  
Offset Style.  
Square Edge.

**FINISHES:**

- Polished Chrome (99)
- Brushed Nickel (81)
- Matte Black (48)
- Brushed Brass (78)
- Cava (37)

**SPECIAL FINISHES AVAILABLE:** Please see our website for full list samples

**WARRANTY:**

Lifetime Limited (Residential Use)  
Three Years (Commercial Use)

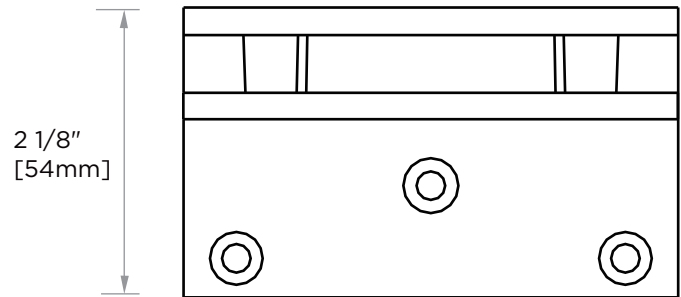
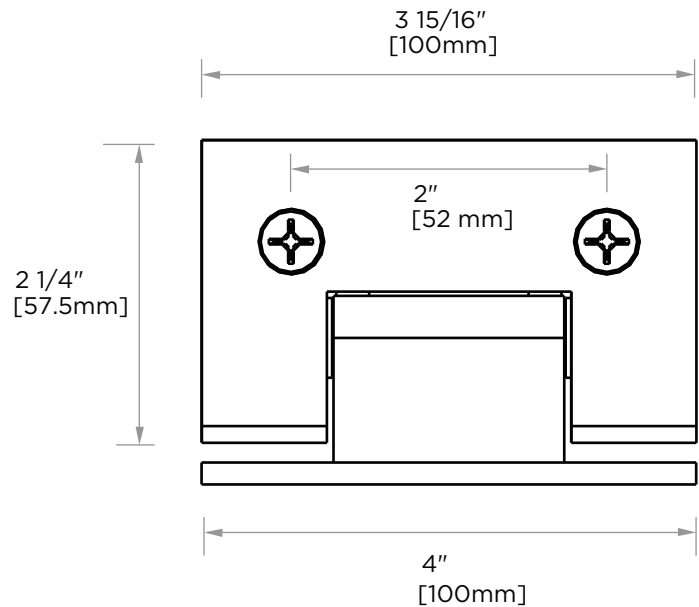

NOTE: Dimensions and specifications are subject to change without notice.

### WALL MOUNT BACK PLATE HEAVY DUTY HINGE

#### SPECIFICATIONS

For 10mm (3/8") and 12mm (1/2") glass  
 -use 2 hinges, having a maximum weight of 110 lbs (50kg), and a width of 36"(914mm).  
 -use 3 hinges, having a maximum weight of 140 lbs (63kg), and a width of 36" (914mm).

#### ASSEMBLY

for 3/8"(10mm) glass use thick rubber on each side  
 for 1/2"(12mm) glass use thin rubber on each side

#### CAUTION

For public safety, we recommend only using tempered or safety glass.  
 (But verify with local building codes.)  
 DO NOT USE POWER TOOLS FOR MOUNTING THESE HINGES

#### CLEANING

See reverse side for instructions

| *Maximum Door Capacities | 3/8" (10mm) Glass Weight | Width      | 1/2" (12mm) Glass Weight | Width      |
|--------------------------|--------------------------|------------|--------------------------|------------|
| Using 2 Hinges           | 110 lbs.(50kg)           | 36"(914mm) | 110 lbs.(50kg)           | 36"(914mm) |
| Using 3 Hinges           | 140 lbs.(63kg)           | 36"(914mm) | 140 lbs.(63kg)           | 36"(914mm) |

\*NOTE: Do not exceed either maximum weight or width when choosing proper quantity of hinges.

### WALL MOUNT BACK PLATE HEAVY DUTY HINGE

Rectangular Cut-out Option

IMPORTANT:  
Project measurements from the edge of the glass

"Mouse-Ear" Cut-out Option

NOTE: Dimensions and specifications are subject to change without notice.