



BRADFORDSERIES
GLASS CLAMP

50031

PRODUCT NAME: GLASS CLAMP

PRODUCT CODE: 50031

MATERIAL: All-brass construction

KEY FEATURES: Glass Clamp.
Glass to Wall.
Square Edge.

FINISHES:

- Polished Chrome (99)
- Brushed Nickel (81)
- Matte Black (48)
- Brushed Brass (78)
- Cava (37)

Please see our website for full list samples

SPECIAL FINISHES AVAILABLE:

WARRANTY:

Lifetime Limited (Residential Use)
Three Years (Commercial Use)

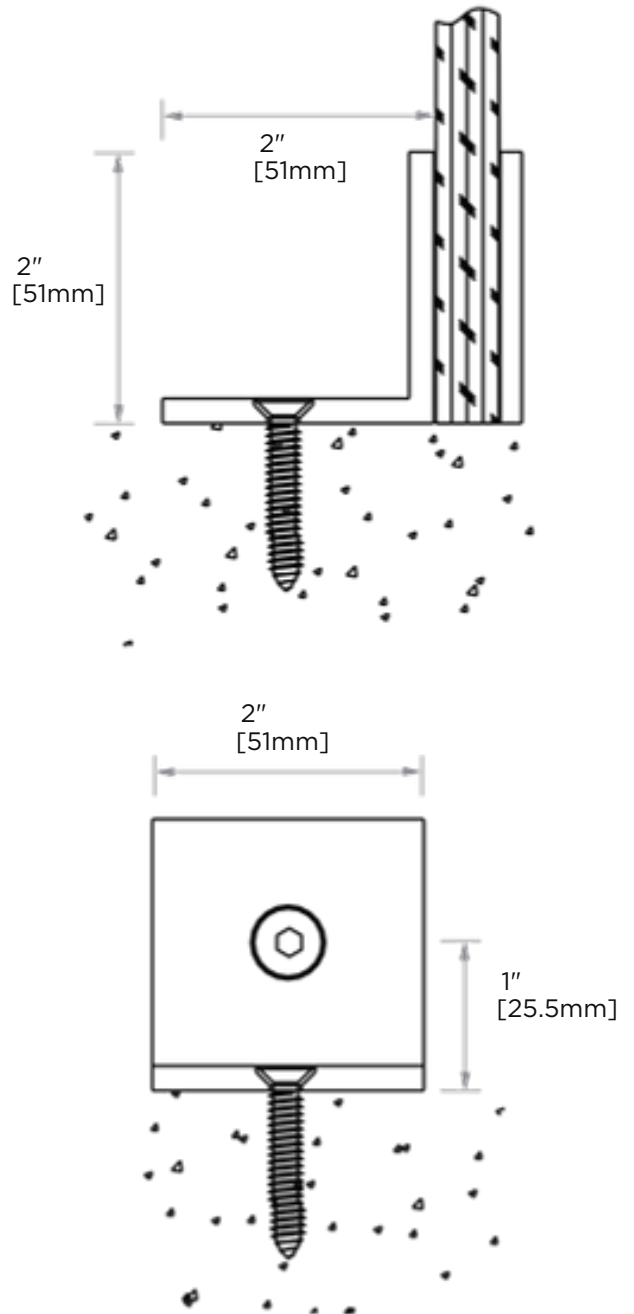

NOTE: Dimensions and specifications are subject to change without notice.

Specifications:

Material: Solid brass
 Glass Thickness Range: 3/8" (10mm) to 1/2" (12mm)
 Hole Size Required: 5/8" (16mm) or 3/4" (19mm)
 Includes: Mounting screw and gaskets

Template Shown on Next Page

GLASS CLAMPS

Square with Large Leg

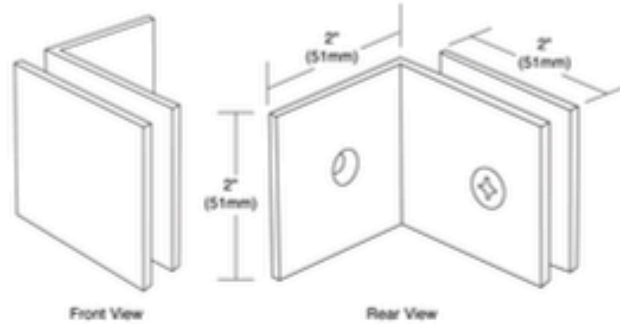

Specifications:

Material: Solid brass
 Glass Thickness Range: 3/8" (10mm) to 1/2" (12mm)
 Hole Size Required: 5/8" (16mm) or 3/4" (19mm)
 Includes: Mounting screw and gaskets

Template Shown on Next Page

GLASS CLAMPS

Beveled with Large Leg

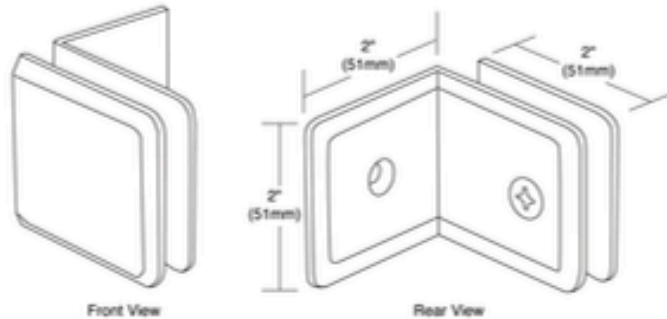

4147

TYPICAL INSTALLATION

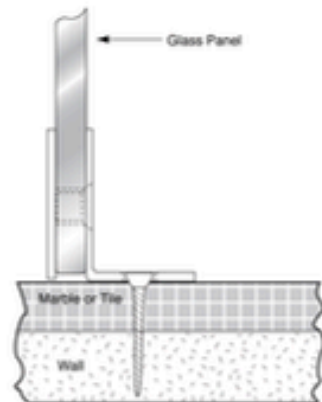

TEMPLATE

Important: Project measurements from the edge of the glass.

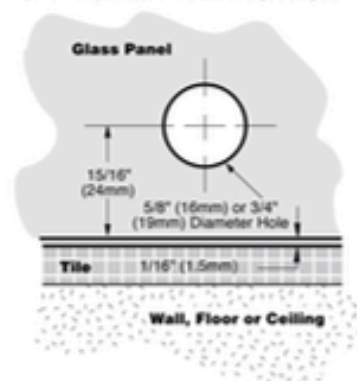

GLASS CLAMPS

THE TEMPLATE ON THIS PAGE APPLIES TO THE FOLLOWING CLAMPS:



NOTE: Dimensions and specifications are subject to change without notice.